

EXERCISE- 3 (A)**Question 1:**

What do you understand by a simple machine?

Solution 1:

A machine is a device by which we can either overcome a large resistive force at some point by applying a small force at a convenient point and in a desired direction or by which we can obtain a gain in the speed.

Question 2:

State four ways in which machines are useful to us?

Solution 2:

Machines are useful to us in the following ways:

- (1) In lifting a heavy load by applying a less effort.
- (2) In changing the point of application of effort to a convenient point.
- (3) In changing the direction of effort to a convenient direction.
- (4) For obtaining a gain in speed.

Question 3:

Name a machine for each of the following use:

- (a) to multiply force
- (b) To change the point of application of force
- (c) To change the direction of force
- (d) To obtain gain in speed

Solution 3:

- (a) To multiply force: a jack is used to lift a car.
- (b) To change the point of application of force: the wheel of a cycle is rotated with the help of a chain by applying the force on the pedal.
- (c) To change the direction of force: a single fixed pulley is used to lift a bucket full of water from the well by applying the effort in the downward direction instead of applying it upwards when the bucket is lifted up without the use of pulley.
- (d) To obtain gain in speed: when a pair of scissors is used to cut the cloth, its blades move longer on cloth while its handles move a little.

Question 4:

What is the purpose of a jack in lifting a car by it?

Solution 4:

The purpose of jack is to make the effort less than the load so that it works as a force multiplier.

Question 5:

What do you understand by an ideal machine? How does it differ from a practical machine?

Solution 5:

An ideal machine is a machine whose parts are weightless and frictionless so that there is no dissipation of energy in any manner. Its efficiency is 100%, i.e. the work output is equal to work input.

Ideal machine	Practical machine
1. Efficiency is 100%.	1. Efficiency is less than 100%
2. Its parts are weightless, elastic and perfectly smooth.	2. Its parts are not weightless, elastic or perfectly smooth.
3. There is no loss in energy due to friction.	3. There is always some loss of energy due to friction.
4. Work output of such a machine is equal to the work input.	4. Work output is always less than the work input.

Question 6:

Explain the term mechanical advantage. State its unit.

Solution 6:

The ratio of the load to the effort is called mechanical advantage of the machine. It has no unit.

Question 7:

Define the term velocity ratio, state its unit.

Solution 7:

The ratio of the velocity of effort to the velocity of the load is called the velocity ratio of machine. It has no unit.

Question 8:

How is mechanical advantage related to the velocity ratio for an ideal machine?

Solution 8:

For an ideal machine mechanical advantage is numerically equal to the velocity ratio.

Question 9:

Define the term efficiency of a machine. Why is a machine not 100% efficient?

Solution 9:

It is the ratio of the useful work done by the machine to the work put into the machine by the effort.

In actual machine there is always some loss of energy due to friction and weight of moving parts, thus the output energy is always less than the input energy.

Question 10:

When does a machine act as (a) a force multiplier (b) a speed multiplier Can a machine act as a force multiplier and a speed multiplier simultaneously?

Solution 10:

- (a) A machine acts as a force multiplier when the effort arm is longer than the load arm. The mechanical advantage of such machines is greater than 1.
- (b) A machine acts a speed multiplier when the effort arm is shorter than the load arm. The mechanical advantage of such machines is less than 1.

It is not possible for a machine to act as a force multiplier and speed multiplier simultaneously. This is because machines which are force multipliers cannot gain in speed and vice-versa.

Question 11:

State the relationship between mechanical advantage, velocity ratio and efficiency. Name the term that will not change for a machine of a given design.

Solution 11:

Mechanical advantage is equal to the product of velocity ratio and efficiency.

$$M.A = \eta \times V.R$$

For a machine of a given design, the velocity ratio does not change.

Question 12:

Derive the relationship between mechanical advantage, velocity ratio and efficiency of a machine.

Solution 12:

Let a machine overcome a load L by the application of an effort E . In time t , let the displacement of effort be d_E and the displacement of load be d_L .

$$\begin{aligned} \text{Work input} &= \text{Effort} \times \text{displacement of effort} \\ &= E \times d_E \end{aligned}$$

$$\begin{aligned} \text{Work output} &= \text{Load} \times \text{displacement of load} \\ &= L \times d_L \end{aligned}$$

$$\text{Efficiency } \eta = \frac{\text{work output}}{\text{work input}}$$

$$\eta = \frac{L \times d_L}{E \times d_E} = \frac{L}{E} \times \frac{1}{d_E/d_L}$$

$$\text{But } \frac{L}{E} = M.A$$

$$\frac{d_E}{d_L} = V.R$$

$$\eta = \frac{M.A}{V.R}$$

$$M.A = \eta \times V.R$$

Thus, mechanical advantage of a machine is equal to the product of its efficiency and velocity ratio.

Question 13:

How is the mechanical advantage related with the velocity ratio for an actual machine? State whether the efficiency of such a machine is equal to 1, less than 1 or more than 1.

Solution 13:

The mechanical advantage for an actual machine is equal to the product of its efficiency and velocity ratio.

$$M.A = V.R \times \eta$$

The efficiency of such a machine is always less than 1, i.e. $\eta < 1$. This is because there is always some loss in energy in form of friction etc.

Question 14:

State reason why is mechanical advantage less than the velocity ratio for an actual machine.

Solution 14:

This is because the output work is always less than the input work, so the efficiency is always less than 1 because of energy loss due to friction.

$$M.A = V.R \times \eta$$

Question 15:

What is a lever? State its principle.

Solution 15:

A lever is a rigid, straight or bent bar which is capable of turning about a fixed axis.

Principle: A lever works on the principle of moments. For an ideal lever, it is assumed that the lever is weightless and frictionless. In the equilibrium position of the lever, by the principle of moments,

Moment of load about the fulcrum = Moment of the effort about the fulcrum.

Question 16:

Write down a relation expressing the mechanical advantage of a lever.

Solution 16:

$$M.A = \frac{\text{Effort arm}}{\text{Load arm}}$$

This is the expression of the mechanical advantage of a lever.

Question 17:

Name the three classes of levers and distinguish between them. Give two examples of each class.

Solution 17:

The three classes of levers are:

- (i) Class I levers: In these types of levers, the fulcrum F is in between the effort E and the load L. Example: a seesaw, a pair of scissors, crowbar.
- (ii) Class II levers: In these types of levers, the load L is in between the effort E and the fulcrum F. The effort arm is thus always longer than the load arm. Example: a nut cracker, a bottle opener.
- (iii) Class III levers: In these types of levers, the effort E is in between the fulcrum F and the load L and the effort arm is always smaller than the load arm. Example: sugar tongs, forearm used for lifting a load.

Question 18:

Give one example each of a class I lever where mechanical advantage is (a) more than one, and (b) less than one.

What is the use of the lever if its mechanical advantage is less than 1?

Solution 18:

- (a) More than one: shears used for cutting the thin metal sheets.
- (b) Less than one: a pair of scissors whose blades are longer than its handles.

When the mechanical advantage is less than 1, the levers are used to obtain gain in speed. This implies that the displacement of load is more as compared to the displacement of effort.

Question 19:

A pair of scissors and a pair of pliers both belongs to the same class of levers. Name the class of lever. Which one has the mechanical advantage less than 1?

Solution 19:

A pair of scissors and a pair of pliers both belong to class I lever.

A pair of scissors has mechanical advantage less than 1.

Question 20:

Explain why scissors for cutting cloth may have blades longer than the handles, but shears for cutting metals have short blades and long handles.

Solution 20:

A pair of scissors used to cut a piece of cloth has blades longer than the handles so that the blades move longer on the cloth than the movement at the handles.

While shears used for cutting metals have short blades and long handles because as it enables us to overcome large resistive force by a small effort.

Question 21:

Fig 3.12, shows a uniform metre scale of weight W supported on a fulcrum at the 60 cm mark by applying the effort E at the 90 cm mark.

(a) state with reason whether the weight W of the scale is greater than, less than or equal to the effort E .

(b) Find the mechanical advantage in an ideal case.

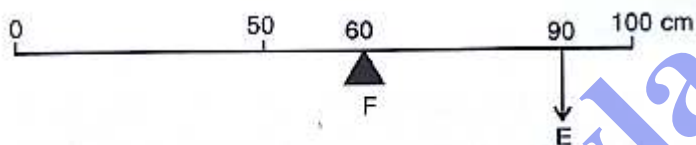

Fig. 3.12

Reason: The weight W of a uniform metre scale acts at 50 cm mark. Since distance of weight of scale from fulcrum F is less than that of the effort E , so the weight W of scale is greater than the effort E .

Solution 21:

(a) The weight W of the scale is greater than E .

It is because arm on the side of effort E is 30 cm and on the side of weight of scale is 10 cm. So, to balance the scale, weight W of scale should be more than effort E .

(b)

$$MA = \frac{\text{Effort arm}}{\text{Load arm}}$$

Here, effort arm = 30 cm

Load arm = 10 cm

$$\therefore M.A = \frac{30}{10} = 3$$

Question 22:

Which type of lever has a mechanical advantage always more than one? Give one example. What change can be made in this lever to increase its mechanical advantage?

Solution 22:

Class II lever always have a mechanical advantage more than one.

Example: a nut cracker.

To increase its mechanical advantage we can increase the length of effort arm.

Question 23:

Draw a diagram of a lever which is always used as a force multiplier. How is the effort arm related to the load arm in such a lever?

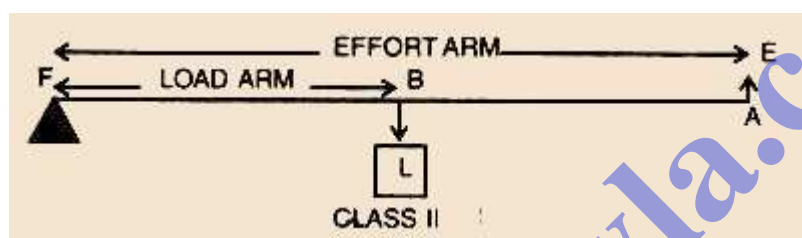
Solution 23:**Diagram:**

The effort arm is longer than load arm in such a lever.

Question 24:

Explain why the mechanical advantage of a Class II type of lever is always more than 1.

Solution 24:

In these types of levers, the load L is in between the effort E and the fulcrum F. So, the effort arm is thus always longer than the load arm. Therefore $M.A > 1$.

Question 25:

Draw a labelled diagram of a class II lever. Give one example of such a lever.

Solution 25:**Diagram:**

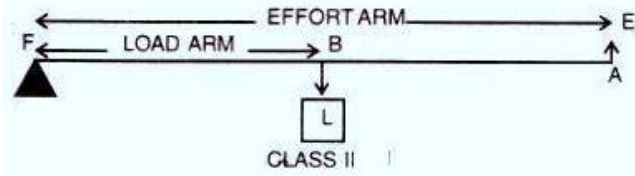

Example: a bottle opener.

Question 26:

Fig 3.13 shows a nut cracker.

(a) In the diagram, mark the position of the fulcrum F and the line of action of load L and effort E.

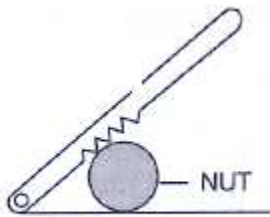
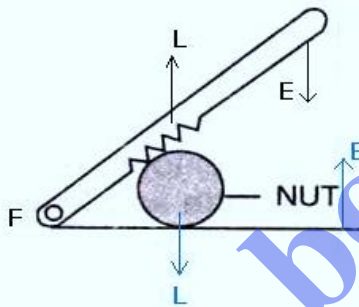

Fig. 3.13

(b) Name the class of lever.

Solution 26:

(a)



(b) The nut cracker is class II lever.

Question 27:

The diagram below shows a wheel barrow. Mark position of fulcrum F and draw arrows to show the directions of load L and effort E. What class of lever is the wheel barrow? Give one more example of the same class of lever.

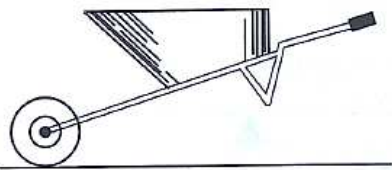
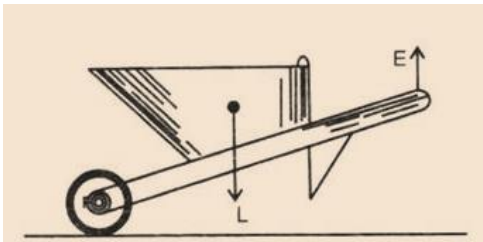

Fig. 3.14

Solution 27:

The wheel barrow is a class II lever. One more example of this class is a nut cracker.

Question 28:

State the kind of lever which always has the mechanical advantage less than 1. Draw a labelled diagram of such lever.

Solution 28:

Class III levers always have mechanical advantage less than one.

Diagram:

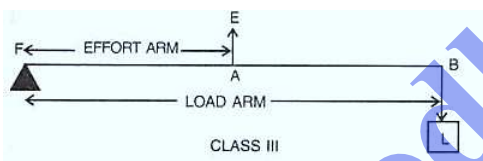
**Question 29:**

Explain why the mechanical advantage of the class III type of lever is always less than 1.

Solution 29:

In these types of levers, the effort is in between the fulcrum F and the load L and so the effort arm is always smaller than the load arm. Therefore $M.A. < 1$.

Question 30:

Class III levers have mechanical advantage less than one. Why are they then used?

Solution 30:

With levers of class III, we do not get gain in force, but we get gain in speed, that is a longer displacement of load is obtained by a smaller displacement of effort.

Question 31:

What type of lever is formed by the human body while (a) raising a load on the palm, (b) raising the weight of body on toes?

Solution 31:

(a) Class III.

Here, the fulcrum is the elbow of the human arm. Biceps exert the effort in the middle and load on the palm is at the other end.

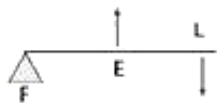
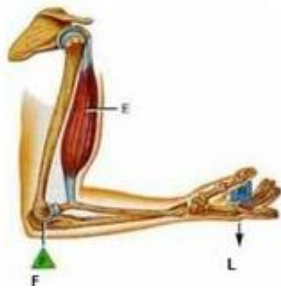

Third-Class Lever

(b) Class II.

Here, the fulcrum is at toes at one end, the load (i.e. weight of the body) is in the middle and effort by muscles is at the other end.



Second-Class Lever

Question 32:

Indicate the positions of load, effort and fulcrum in the forearm shown below in Fig 3.15 Name class of lever.

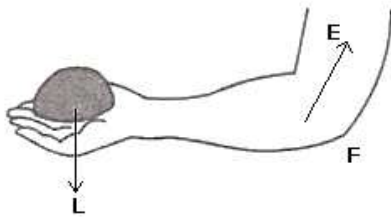
**Solution 32:**

It is Class III lever.

Question 33:

Draw a labelled sketch of a class III lever. Give one example of this kind of lever.

Solution 33:

Diagram:

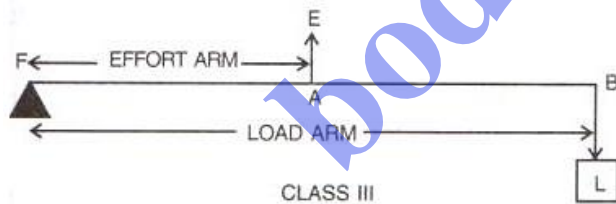

Examples: foot treadle.

Question 34:

Give example of each class of lever in a human body?

Solution 34:

- (i) Class I lever in the action of nodding of the head: In this action, the spine acts as the fulcrum, load is at its front part, while effort is at its rear part.

- (ii) Class II lever in raising the weight of the body on toes: The fulcrum is at toes at one end, the load is in the middle and effort by muscles is at the other end.
- (iii) Class III lever in raising a load by forearm: The elbow joint acts as fulcrum at one end, biceps exerts the effort in the middle and a load on the palm is at the other end.

Question 35:

State the class of levers and the relative positions of load (L) effort (E) and fulcrum (F) in (a) a bottle opener, (b) sugar tongs.

Solution 35:

- (a) A bottle opener is a lever of the second order, as the load is in the middle, fulcrum at one end and effort at the other.

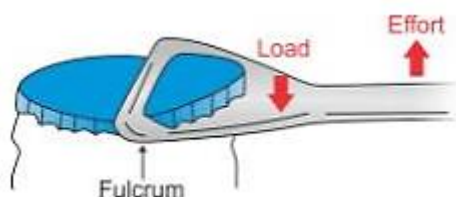

Bottle opener

- (b) Sugar tongs is a lever of the third order as the effort is in the middle, load at one end and fulcrum at the other end.

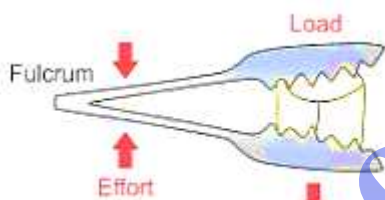

Sugar tongs

Question 36:

Draw Diagrams to illustrate the position of fulcrum load and effort, in each of the following:

- (a) A seesaw
- (b) A common balance
- (c) A nut cracker
- (d) Forceps

Solution 36:

- (a) A seesaw

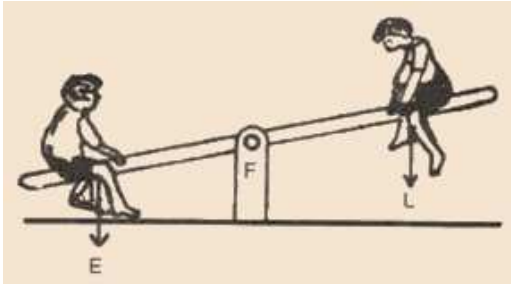

(b) A common balance



(c) A nut cracker

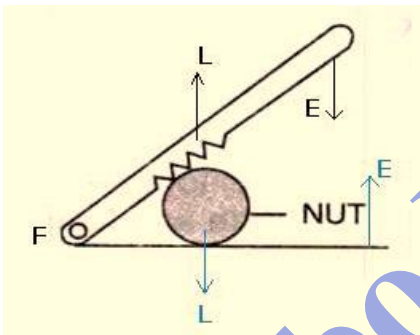

(d) Forceps.

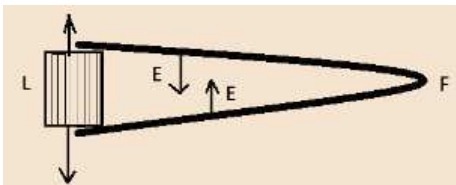
**Question 37:**

Classify the following into levers as class I, class II or class III.

- (a) a door
- (b) a catapult

- (c) a wheel barrow
- (d) a fishing rod.

Solution 37:

- a. Class II
- b. Class I
- c. Class II
- d. Class III

MULTIPLE CHOICE TYPE:**Question 1:**

Mechanical advantage (M.A), load (L) and effort (E) are related as:

- (a) $M.A. = \frac{L}{E}$
- (b) $M.A \times E = L$
- (c) $E = M.A. \times L$
- (d) None of these

Solution 1:

$$M.A. \times E = L$$

Question 2:

The correct relationship between the mechanical advantage (M.A), the velocity ratio (V.R) and the efficiency (η) is:

- (a) $M.A. = \eta \times v.r.$
- (b) $V.R. = \eta \times M.A.$
- (c) $\eta = M.A. \times V.R.$
- (d) None of these

Solution 2:

$$M.A. = \eta \times V.R$$

Question 3:

Which of the following statements is not true for a machine:

- (a) It always has efficiency less than 100%
- (b) its mechanical advantage can be less than 1.
- (c) It can also be used as a speed multiplier
- (d) It can have a mechanical advantage greater than the velocity ratio.

Solution 3:

- (d) It can have a mechanical advantage greater than the velocity ratio.

Reason: If the mechanical advantage of a machine is greater than its velocity ratio, then it would mean that the efficiency of a machine is more than 100%, which is practically not possible.

Question 4:

The lever for which the mechanical advantage is less than 1 has:

- (a) fulcrum at mid-point between load and effort.
- (b) Load between effort and fulcrum
- (c) effort between fulcrum and load
- (d) Load and effort acting at the same point

Solution 4:

- (c) effort is between fulcrum and load

Hint: Levers, for which the mechanical advantage is less than 1, always have the effort arm shorter than the load arm.

Question 5:

Class II levers are designed to have:

- (a) M.A. = V.R.
- (b) M.A. > V.R.
- (c) M.A > 1
- (d) M.A < 1

Solution 5:

- (c) M.A > 1

Hint: In class II levers, the load is in between the effort and fulcrum. Thus, the effort arm is always longer than the load arm and less effort is needed to overcome a large load. Hence, M.A > 1

NUMERICALS:**Question 1:**

A crowbar of length 120 cm has its fulcrum situated at a distance of 20 cm from the load. Calculate the mechanical advantage of the crowbar.

Solution 1:

Total length of crowbar = 120 cm

Load arm = 20 cm

Effort arm = 120 – 20 = 100 cm

Mechanical advantage M.A = $\frac{\text{Effort arm}}{\text{Load arm}}$

$$\text{M.A} = \frac{100}{20} = 5$$

Question 2:

A 4 m long rod of negligible weight is to be balanced about a point 125 cm from one end. A load of 18 kgf is suspended at a point 60 cm from the support on the shorter arm.

- (a) a weight W is placed 250 cm from the support on the longer arm Find W.
 (b) If W = 5 kgf, where must it be kept to balance the rod?
 (c) To which class of lever does it belong?

Solution 2:

Total length of rod = 4 m = 400 cm

- (a) 18kgf load is placed at 60 cm from the support.
 W kgf weight is placed at 250 cm from the support.

By the principle of moments

$$18 \times 60 = W \times 250$$

$$W = 4.32 \text{ kgf}$$

- (b) Given W = 5 kgf
 18kgf load is placed at 60 cm from the support.
 Let 5 kgf of weight is placed at d cm from the support.

By the principle of moments

$$18 \times 60 = 5 \times d$$

$$d = 216 \text{ cm from the support on the longer arm}$$

- (c) It belongs to class I lever.

Question 3:

A pair of scissors has its blades 15 cm long, while its handles are 7.5 cm long. What is its mechanical advantage?

Solution 3:

Effort arm = 7.5 cm

Load arm = 15 cm

$$\text{Mechanical advantage } M.A = \frac{\text{Effort arm}}{\text{Load arm}} = \frac{7.5}{15} = 0.5$$

Question 4:

A force of 5 kgf is required to cut a metal sheet. A shears used for cutting the metal sheet has its blades 5 cm long, while its handles is 10 cm long. What effort is needed to cut the sheet?

Solution 4:

Effort arm = 10 cm

Load arm = 5 cm

$$\text{Mechanical advantage} = M.A = \frac{\text{Effort arm}}{\text{Load arm}} = \frac{10}{5} = 2$$

Load = 5kgf

$$\text{Effort} = \frac{\text{Load}}{M.A} = \frac{5}{2} = 2.5 \text{ kgf}$$

Question 5:

Fig 3.16 below shows a lever in use.

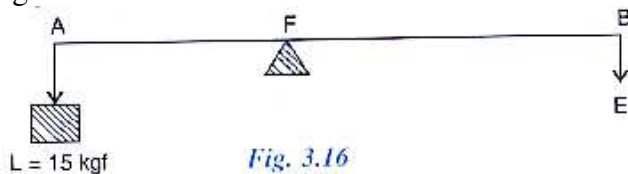

- (a) To which class of lever does it belong?
 (b) If $AB = 1\text{m}$, $AF = 0.4\text{m}$, find its mechanical advantage,
 (c) calculate the value of E.

Solution 5:

- (a) This is a class I lever.
 (b) Given $AB=1\text{m}$, $AF=0.4\text{m}$ and $BF=0.6\text{m}$
 Mechanical advantage $M.A = \frac{BF}{AF} = \frac{0.6}{0.4} = 1.5$

- (c) Load = 15kgf
 Effort = $\frac{\text{Load}}{M.A} = \frac{15}{1.5} = 10\text{kgf}$

Question 6:

A man uses a crowbar of length 1.5 m to raise a load of 75 kgf by putting a sharp edge below the bar at a distance 1 m from his hand. Draw a diagram of the arrangement showing the fulcrum (F), load (L) and effort (E) with their directions. State the kind of lever. Calculate: (i) load arm, (ii) effort arm, (iii) mechanical advantage and (iv) the effort needed.

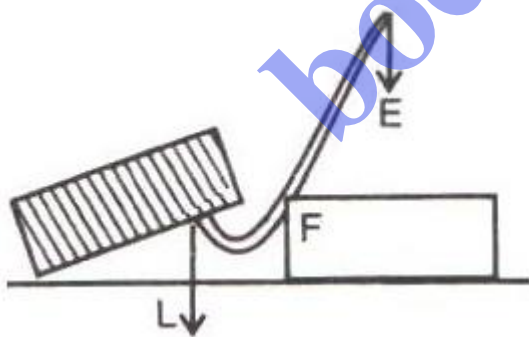
Solution 6:**Diagram**

Crowbar is a class I lever.

- (i) Total length of crowbar = 1.5m
 Effort arm = 1 m
 Load arm = $1.5 - 1 = 0.5\text{m}$
 (ii) Effort arm = 1m

$$(iii) \text{ Mechanical advantage } M.A = \frac{\text{Effort arm}}{\text{Load arm}} = \frac{1}{0.5} = 2$$

(iv) The effort needed

$$\text{Effort} = \frac{\text{Load}}{M.A} = \frac{75}{2} = 37.5 \text{ kgf}$$

Question 7:

A pair of scissors is used to cut a piece of a cloth by keeping it at a distance 8.0 cm from its rivet and applying an effort of 10 kgf by fingers at a distance 2.0 cm from the rivet. (a) Find : (i) the mechanical advantage of scissors and (ii) the load offered by the cloth (b) How does the pair of scissors act: as a force multiplier or as speed multiplier?

Solution 7:

Effort arm = 2 cm

Load arm = 8.0 cm

Given effort = 10 kgf

$$(i) \text{ Mechanical advantage } M.A = \frac{\text{Effort arm}}{\text{Load arm}} = \frac{2}{8} = 0.25$$

$$(ii) \text{ load} = M.A \times \text{effort} = 0.25 \times 10 = 2.5 \text{ kgf}$$

The pair of scissors acts as a speed multiplier because $MA < 1$.

Question 8:

Fig 3.17 below shows a lever in use.



(a) To which class of lever does it belong?

(b) If $FA = 80 \text{ cm}$, $AB = 20 \text{ cm}$, find its mechanical advantage.

(c) Calculate the value of E.

Solution 8:

(a) This is a class II lever.

(b) Given: $FA = 80 \text{ cm}$, $AB = 20 \text{ cm}$, $BF = FA + AB = 100 \text{ cm}$

$$\text{Mechanical advantage } M.A = \frac{BF}{AF} = \frac{100}{80} = 1.25$$

$$(c) \text{ Effort } (E) = \frac{\text{Load } (L)}{M.A} = \frac{5}{1.25} = 4 \text{ Kgf}$$

Question 9:

Fig 3.18 below shows the use of a lever.



- (a) State the principle of moments as applied to the above lever.
 (b) Give an example of this class of lever.
 (c) If $FA = 10\text{ cm}$, $AB = 500\text{ cm}$ calculate: (i) the mechanical advantage and (ii) the minimum effort required to lift the load.

Solution 9:

- (a) The principle of moments: Moment of the load about the fulcrum = moment of the effort about the fulcrum

$$FB \times \text{Load} = FA \times \text{Effort}$$

- (b) Sugar tongs the example of this class of lever.

- (c) Given: $FA = 10\text{ cm}$, $AB = 500\text{ cm}$, $BF = 500 + 10 = 510\text{ cm}$.

The mechanical advantage

$$M.A = \frac{AF}{BF} = \frac{10}{510} = \frac{1}{51}$$

The minimum effort required to lift the load

$$\text{Effort} = \frac{\text{Load}}{M.A} = \frac{50}{\frac{1}{51}} = 2550\text{ N}$$

Question 10:

Fig 3.19 below shows a wheel barrow of mass 15 kg carrying a load of 30 kgf with its centre of gravity at A. The points B and C are the centre of wheel and tip of the handle such that the horizontal distance $AB = 20\text{ cm}$ and $AC = 40\text{ cm}$.

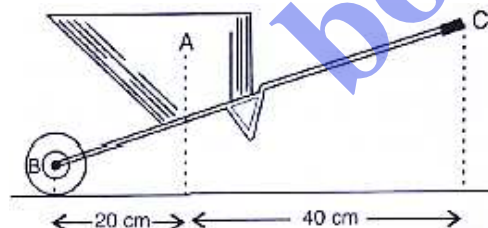

Calculate: (i) the load arm, (ii) the effort arm, (iii) the mechanical advantage and (iv) the minimum effort required to keep the leg just off the ground.

Solution 10:

- (a) (i) Load arm $AF = 20\text{ cm}$
 (ii) Effort arm $CF = 60\text{ cm}$
 (iii) Mechanical advantage $M.A = \frac{CF}{AF} = \frac{60}{20} = 3$
 (iv) Total load = $30 + 15 = 45\text{ kgf}$

$$\text{Effort} = \frac{\text{Load}}{\text{M.A}} = \frac{30+15}{3} = 15 \text{ kgf}$$

Question 11:

A fire tongs has arms 20 cm long. It is used to lift a coal of weight 1.5 kgf by applying an effort at a distance 15 cm from the fulcrum. Find: (i) the mechanical advantage of fire tongs and (ii) the effort needed.

Solution 11:

Fire tongs has its arms = 20 cm

Effort arm = 15 cm

Load arm = 20 cm

(i) Mechanical advantage $\text{M.A} = \frac{\text{Effort arm}}{\text{Load arm}} = \frac{15}{20} = 0.75$

(ii) Effort $= \frac{\text{Load}}{\text{M.A}} = \frac{1.5}{0.75} = 2.0 \text{ kgf}$

EXERCISE – 3(B)**Question 1:**

What is an inclined plane? Give two examples where it is used to raise a heavy load with less effort?

Solution 1:

Inclined plane: An inclined plane is a sloping surface that behaves like a simple machine whose mechanical advantage is always greater than 1.

Example: the inclined plane is used to load a truck or to take the scooter from road into the house on a higher level. Inclined planes are used to reach the bridge over the railway tracks at a railway station.

Question 2:

‘The force needed to push a load up an inclined plane is less than the force needed to lift it directly’ Give a reason.

Solution 2:

Since less effort is needed in lifting a load to a higher level by moving over an inclined plane as compared to that in lifting the load directly, an inclined plane acts as a force multiplier. This is because the mechanical advantage of an inclined plane is always greater than 1.

Question 3:

Write an expression for the mechanical advantage of an inclined plane in terms of its length l and vertical height h .

Solution 3:

The expression for the mechanical advantage of an inclined plane in terms of its length l and vertical height h is:

$$M.A = \frac{l}{h}$$

Question 4:

State whether the mechanical advantage of an inclined plane is equal to 1, less than 2 or greater than 1?

Solution 4:

Mechanical advantage of an inclined plane is always greater than 1.

Question 5:

What is a gear system? Explain its working.

Solution 5:

Gear system: A gear system is a device to transfer precisely the rotator motion from one point to the other. A gear is a wheel with teeth around its rim. The teeth act as the components of a machine and they transmit rotational motion to the wheel by successively engaging the teeth of the other rotating gear.

Working: Each tooth of a gear acts like a small lever of class I. A gear when in operation, can be considered as a lever with an additional property that it can be continuously rotated instead of moving back and forth as is the case with an ordinary lever. Each gear wheel is mounted on an axle which rotates at a speed depending upon the motion transmitted to it. The gear wheel closer to the source of power is called the driver, while the gear wheel which receives motion from the driver is called the driven gear. The driven gear rotates in a direction opposite to the driving gear when the two gears make an external contact. On the other hand, if the gears make an internal contact, both gears rotate in the same direction.

Question 6:

Explain how a gear system can be used to obtain:

- (a) gain in speed
- (b) gain in torque and
- (c) Change in direction of rotation. Given one example for each.

Solution 6:

- (a) A gear system can be used to obtain gain in speed when the bigger wheel drives the smaller wheel, i.e. when the driving gear has more number of teeth than the driven gear.

To obtain gain in speed, the gear ratio should be more than one. Mathematically,

$$\text{Gain in speed} = \frac{\text{Number of teeth in driving wheel}}{\text{Number of teeth in driven wheel}}$$

Example: A toy motor car uses the gear principle to obtain gain in speed. It has a key and spring on the axle fitted with a driving gear having more teeth which engages the driven gear having fewer teeth. The wheels of the car are fitted on the axle of the driven gear. When the key is turned clockwise (or the toy car is pulled back by hand) the spring is wound up. On releasing the key (or the toy car), the spring turns the driving gear anti-clockwise, which in turn rotates the wheels of the toy car clockwise and the car moves forward at a greater speed.

- (b) A gear system can be used to obtain gain in torque when the smaller wheel drives the bigger wheel, i.e. when the driving gear has less number of teeth than the driven gear. To obtain gain in torque, the gear ratio should be less than one. Mathematically,

$$\text{Gain in torque} = \frac{\text{Number of teeth in driven wheel}}{\text{Number of teeth in driving wheel}}$$

Example: While ascending a hill, an automobile driver changes gears and puts the driving gear of less number of teeth with a driven gear of more number of teeth. By doing so, he obtains a gain in torque, as more torque is required to go up the hill than to move along a level road.

- (c) A gear system can be used to obtain change in direction when both the wheels of the gear system have the same number of teeth. Two gears mesh together in such a way that the driven gear rotates in direction opposite to the driving gear without any gain in speed or torque. So, if the driving gear turns clockwise, the driven gear turns counterclockwise.

To obtain change in direction, the gear ratio should be equal to 1.

Example: In a car, the differential (a gearbox in the middle of the rear axle of a rear-wheel drive car) uses a cone-shaped bevel gear to turn the driveshaft's power through 90 degrees and turn the back wheels.

Question 7:

Define the following terms in reference to a gear system:

- (a) Driving gear
- (b) Driven gear
- (c) Gear ratio
- (d) Gain in speed
- (e) Gain in torque

Solution 7:

- (a) Driving gear: The gear wheel closer to the source of power is called driving gear.

- (b) Driven gear: The gear wheel which receives motion from the driver is called the driven gear.
- (c) Gear ratio: The ratio of number of teeth in the driving wheel to the number of teeth in the driven wheel is called the gear ratio.
- (d) Gain in speed: The gain in speed is equal to the ratio of speed of rotation of driven wheel to the speed of rotation of the driving wheel.
- (e) Gain in torque: The gain in torque is equal to the ratio of number of teeth in driven gear to the number of teeth in driving gear gives the gain in torque.

Question 8:

What should be the gear ration of a car: equal to 1, less than 1 or greater than 1, while

- (a) gaining speed on the road,
- (b) ascending a hill

Solution 8:

- (a) While gaining speed on the road, the gear ratio should be more than 1.
That is, the driving gear should have more number of teeth than the driven gear.
N
- (b) While ascending a hill more torque is required; thus, the gear ratio should be less than 1.
That is, the driving gear should have less number of teeth than the driven gear.

Question 9:

In a gear system, the gear ration of the driving wheel A and driven wheel B is 10:1. To rotate the driven wheel B in the direction of driving wheel A, the driving wheel A is engaged with other wheel C. what should be the gear ratio of the wheels A and C?

Solution 9:

Given, gear ratio = $\frac{N_A}{N_B} = \frac{10}{1}$

It is possible to obtain a change in direction,

Using wheel C, if the number of teeth in

Wheel C is equal to the number of teeth in wheel A.

$$\therefore N_C = N_A = 10$$

Hence, the gear ratio of wheels A and C:

$$\text{Gear ratio} = \frac{N_A}{N_C} = \frac{10}{10}$$

\therefore The required gear ration is 1:1

MULTIPLE CHOICE TYPE:**Question 1:**

The mechanical advantage of an inclined plane is always:

- (a) less than 1
- (b) equal to 1
- (c) greater than 1
- (d) nothing can be said

Solution 1:

Greater than 1

Hint: $M.A = \frac{1}{\sin\theta}$

NUMERICALS:**Question 1:**

A boy has to lift a load of mass 50 kg to a height of 1 m. (a) what effort is required if he lifts it directly? Take $g = 10 \text{ N kg}^{-1}$ (b) If the boy can exert a maximum effort of 250 N, so he uses an inclined plane to lift the load up. What should be the minimum length of the plank used by him?

Solution 1:

Mass of load $m = 50 \text{ kg}$

Force required to lift a load 1 meter (h) = $mxg = 50 \times 10 = 500 \text{ N}$

The maximum effort exerted by boy $E = 250 \text{ N}$

Load $L = 500 \text{ N}$

Mechanical advantage $M.A = \frac{\text{load}}{\text{effort}} = \frac{500}{250} = 2$

$M.A = \frac{l}{h}$

Height (h) = 1m

Minimum length of plank $l = MA \times h = 2 \times 1 = 2 \text{ m}$

Question 2:

A coolie uses a sloping wooden plank of length 2.0 m to push up a drum of mass 100 kg into the truck at a height 1.0 m.

- (a) What is the mechanical advantage of the sloping plank?
- (b) How much effort is needed to push the drum up into the truck?

What assumption have you made in arriving at the answer in part (b) above?

Solution 2:

Length of sloping wooden plank $l = 2.0 \text{ m}$

Load = 100kgf

Height of inclined plane $h = 1 \text{ m}$

- (a) The mechanical advantage of the sloping plank

$$M.A = \frac{l}{h} = \frac{2}{1} = 2$$

(b) Effort needed to push the drum up into the truck =

$$\text{Effort} = \frac{\text{Load}}{M.A} = \frac{100}{2} = 50 \text{ kgf}$$

Assumption: There is no friction between the drum and the plank.

Question 3:

A gear system has one wheel with 10 teeth and the other wheel with 50 teeth. Calculate the gain in speed and the gain in torque that you can obtain using them. What will be the gear ration in each case?

Solution 3:

Number of teeth in first wheel = 10

Number of teeth in second wheel = 50

For gain in speed, the second wheel of 50 teeth ($N_A = 50$) is used as driving wheel and the first wheel of 10 teeth ($N_B = 10$) is used as driven wheel.

$$\text{Gear ratio} = \frac{N_A}{N_B} = \frac{10}{50} = \frac{1}{5} = 1:5$$

$$\text{Gain in speed} = \frac{N_A}{N_B} = \frac{50}{10} = \frac{5}{1} = 5$$

For gain in torque, the second wheel of 50 teeth ($N_B = 50$) is used as driven wheel and the first wheel of 10 teeth ($N_A = 10$) is used as driving wheel.

$$\text{Gear ratio} = \frac{N_A}{N_B} = \frac{50}{10} = \frac{5}{1} = 5:1$$

$$\text{Gain in torque} = \frac{N_A}{N_B} = \frac{10}{50} = \frac{1}{5} = 1:5$$

$$\text{Gain in torque} = \frac{N_B}{N_A} = \frac{50}{10} = 5$$

Question 4:

A gear system has the driving wheel of radius 2 cm and driven wheel of radius 20 cm.

(a) Find the gear ratio.

(b) If the number of rotations made per minute by the driving wheel is 100, find the number of rotations per minute made by the driven wheel.

(c) If the driven wheel has 40 teeth, find the number of teeth in the driving wheel.

Solution 4:

The radius of driving wheel $r_A = 2\text{cm}$

The radius of driven wheel $r_B = 20\text{cm}$

$$(a) \text{ the gear ratio } \frac{r_A}{r_B} = \frac{2}{20} = 1:10$$

(b) The number of rotations made per minute by the driving wheel is $n_a = 100$

$$\text{The number of rotations made per minute by the driven wheel } nb = \frac{r_A}{r_B} \times na = \frac{2}{20} \times 100 = 10$$

(a) Number of teeth in driven wheel $nb = 40$.

$$\text{Number of teeth in driven wheel } n_a = \frac{r_a}{r_b} \times n_b$$

$$\Rightarrow \frac{2}{20} \times 40 = 4.$$

Question 5:

The driving wheel of a gear system is of radius 1 cm and it has 8 teeth. For twelve rotations of the driving wheel, if the driven wheel makes one rotation find :

- (a) The radius, and
(b) the number of teeth in the driven wheel.

Solution 5:

Given, radius of driving wheel $r_a = 1$ cm

No. of teeth in the driving wheel $N_a = 8$

Speed of rotation of driving wheel $n_a = 12$ rpm

Speed of rotation of driven wheel $n_b = 1$ rpm

(a) Radius of driven wheel $r_b = r_a \times \frac{n_a}{n_b} = 1 \times \frac{12}{1} = 12$ cm

(b) No. of teeth in the driven wheel $N_b = N_a \times \frac{n_a}{n_b} = 8 \times \frac{12}{1} = 96$

EXERCISE – 3 (C)**Question 1:**

What is a single fixed pulley? State its one use.

Solution 1:

Fixed pulley: A pulley which has its axis of rotation fixed in position, is called a fixed pulley. Single fixed pulley is used in lifting a small load like water bucket from the well.

Question 2:

What is the ideal mechanical advantage of a single fixed pulley? Can it be used as a force multiplier?

Solution 2:

The ideal mechanical advantage of a single fixed pulley is 1.
It cannot be used as force multiplier.

Question 3:

Name the pulley which has no gain in mechanical advantage. Explain, why is such a pulley then used?

Solution 3:

There is no gain in mechanical advantage in the case of a single fixed pulley. A single fixed pulley is used only to change the direction of the force applied that is with its use, the effort can be applied in a more convenient direction. To raise a load directly upwards is difficult.

Question 4:

What is the velocity ratio of a single fixed pulley?

Solution 4:

The velocity ratio of a single fixed pulley is 1.

Question 5:

In a single fixed pulley, if the effort moves by a distance x downwards, by what height is the load raised upwards?

Solution 5:

The load rises upwards with the same distance x .

Question 6:

What is a single movable pulley? What is its mechanical advantage in the ideal case?

Solution 6:

Single movable pulley: A pulley, whose axis of rotation is not fixed in position, is called a single movable pulley.

Mechanical advantage in the ideal case is 2.

Question 7:

Name the type of single pulley that can act as a force multiplier. Draw a labelled diagram of the pulley mentioned by you.

Solution 7:

The single pulley that can act as a force multiplier is called pulley. It is supported by two rope and has a mechanical advantage of two.

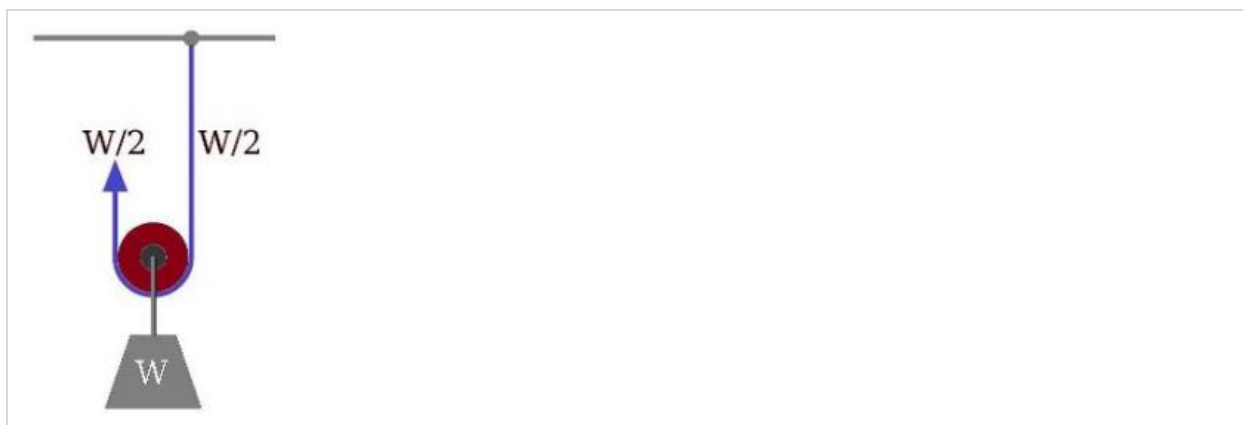
**Question 8:**

Give two reasons why the efficiency of a single movable pulley system is not 100%

Solution 8:

The efficiency of a single movable pulley system is not 100% this is because

- (i) The friction of the pulley bearing is not zero ,
- (ii) The weight of the pulley and string is not zero.

Question 9:

In which direction the force need to applied, when a single pulley is used with a mechanical advantage greater than one? How can you change the direction of force applied without altering its mechanical advantage? Draw a labelled diagram of the system.

Solution 9:

The force should be in upward direction.

The direction of force applied can be changed without altering its mechanical advantage by using a single movable pulley along with a single fixed pulley to change the direction of applied force.

Diagram:

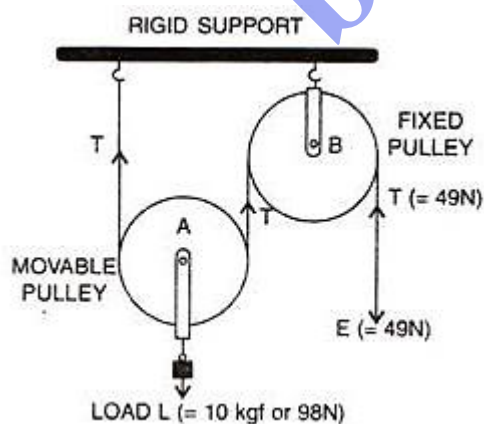

Question 10:

What is the velocity ratio of a single movable pulley?

Solution 10:

The velocity ratio of a single movable pulley is always 2.

Question 11:

In a single movable pulley, if the effort moves by a distance x upwards, by what height is the load raised?

Solution 11:

The load is raised to a height of $x/2$.

Question 12:

Draw a labelled diagram of an arrangement of two pulleys, one fixed and other movable. In the diagram, mark the directions of all forces acting on it. What is the ideal mechanical advantage of the system? How can it be achieved?

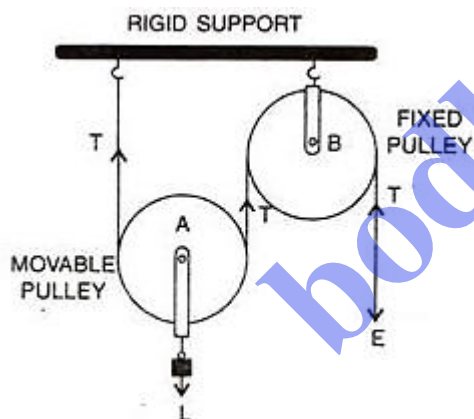
Solution 12:**Diagram:**

Ideal mechanical advantage of this system is 2. This can be achieved by assuming that string and the pulley are massless and there is no friction in the pulley bearings or at the axle or between the string and surface of the rim of the pulley.

Question 13:

The diagram below shows a pulley arrangement.

- In the diagram, mark the direction of tension on each strand of string.
- What is the purpose of the pulley B?

- (c) If the tension is T , Deduce the relation between T and E .
 (d) What is the velocity ratio of the arrangement?
 (e) Assuming that the efficiency of the system is 100%, What is the mechanical advantage?

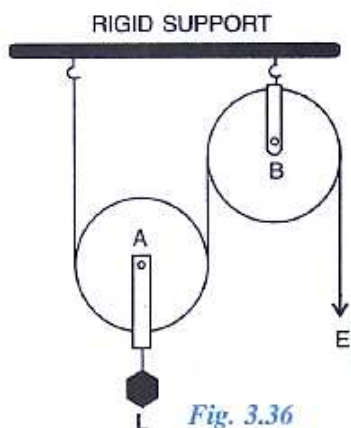

Solution 13:

(a)

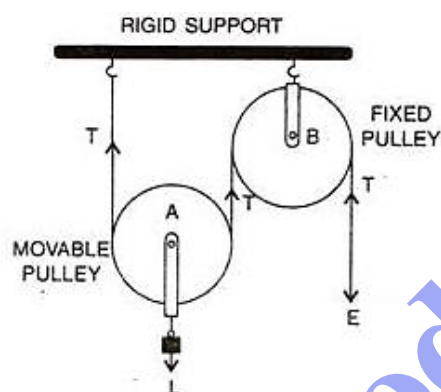

- (b) The fixed pulley B is used to change the direction of effort to be applied from upward to downward.
 (c) The effort E balances the tension T at the free end, so $E=T$
 (d) The velocity ratio of this arrangement is 2.
 (e) The mechanical advantage is 2 for this system (if efficiency is 100%).

Question 14:

Differentiate between a single fixed pulley and a single movable pulley.

Solution 14:

Single fixed pulley	Single movable pulley
1. It is fixed to a rigid support.	1. It is not fixed to a rigid support.
2. Its mechanical advantage is one.	2. Its mechanical advantage is two.

3. Its velocity ratio is one.	3. Its velocity ratio is two.
4. The weight of pulley itself does not affect its mechanical advantage.	4. The weight of pulley itself reduces its mechanical advantage.
5. It is used to change the direction of effort	5. It is used as force multiplier

Question 15:

The Diagram alongside shows an arrangement of three pulleys A, B, and C. The load is marked as L and the effort as E.

(a) Name the Pulleys A, B, and C.

(b) Mark in the diagram the directions of load (L), effort (E) and tension T_1 and T_2 in the two strings.

(c) How are the magnitudes of L and E related to the tension T_1 ?

(d) Calculate the mechanical advantage and velocity ratio of the arrangement.

(e) What assumptions have you made in parts (c) and (d)?

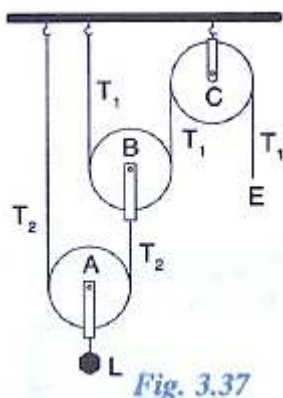
**Solution 15:**

(a) Pulleys A and B are movable pulleys. Pulley C is fixed pulley.

(b)

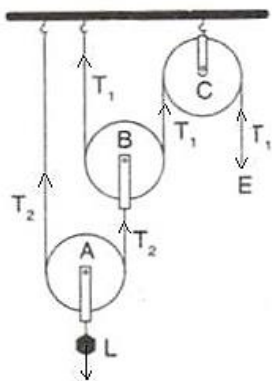

- (c) The magnitude of effort $E = T_1$
 And the magnitude of $L = 2^2 T_1 = 4 T_1$
- (d) The mechanical advantage $= 2^2 = 4$
 The velocity ratio $= 2^2 = 4$
- (e) Assumption: the pulleys A and B are weightless.

Question 16:

Draw a diagram of combination of three movable pulleys with a fixed pulley showing the directions of load, effort and tension in each strand. Find: (i) mechanical advantage, (ii) Velocity ratio and (iii) efficiency of the combination in ideal situation.

Solution 16:

Diagram:

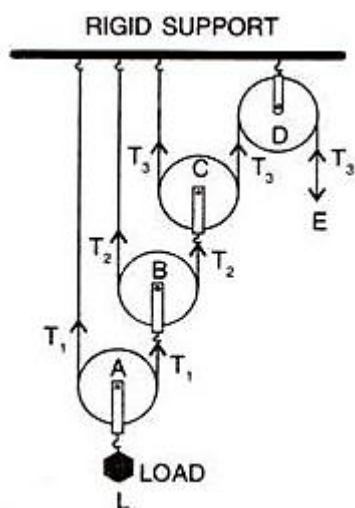

Tension T_1 in the string passing over the pulley A is given as
 $2T_1 = L$ or $T_1 = L/2$

Tension T_2 in the string passing over the pulley B is given as
 $2T_2 = T_1$ or $T_2 = T_1/2 = L/2^2$

Tension T_3 in the string passing over the pulley C is given as
 $2T_3 = T_2$ or $T_3 = T_2/2 = L/2^3$

In equilibrium, $T_3 = E$

$$E = L/2^3$$

Mechanical advantage $= MA = L/E = 2^3$

As one end of each string passing over a movable pulley is fixed, so the free end of string moves twice the distance moved by the movable pulley.

If load L moves up by a distance x , $d_L = x$, effort moves by a distance $2^3 x$, $d_E = 2^3 x$

$$\text{Velocity Ratio VR} = \frac{\text{Distance moved by the effort } d_E}{\text{Distance moved by the load } d_L} = \frac{2^3 x}{x} = 2^3$$

$$\text{Efficiency} = \text{MA}/\text{VR} = 2^3/2^3 = 1 \text{ OR } 100\%$$

Question 17:

What is a block and tackle system of pulleys?

Solution 17:

A block and tackle is a system of two or more pulleys with a rope or cable threaded between them, usually used to lift or pull heavy loads.

Question 18:

Draw a diagram of a block and tackle system of pulleys having a velocity ratio of 5. In your diagram indicate c

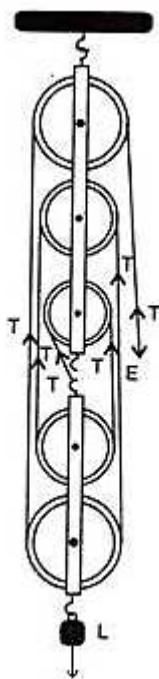
Solution 18:**Question 19:**

Give reasons for the following:

- In a single fixed pulley, the velocity ratio is always more than the mechanical advantage.
- The efficiency of a movable pulley is always less than 100%
- In case of a block and tackle arrangement, the mechanical advantage increases with the increase in the number of pulleys.
- The lower block of a block and tackle pulley system must be of negligible weight.

Solution 19:

- (a) In a single fixed pulley, some effort is wasted in overcoming friction between the strings and the grooves of the pulley; so the effort needed is greater than the load and hence the mechanical advantage is less than the velocity ratio.
- (b) This is because of some effort is wasted in overcoming the friction between the strings and the grooves of the pulley.
- (c) This is because mechanical advantage is equal to the total number of pulleys in both the blocks.
- (d) The efficiency depends upon the mass of lower block; therefore efficiency is reduced due to the weight of the lower block of pulleys.

Question 20:

Name a machine which is used to:

- (a) multiply force,
- (b) multiply speed and
- (c) change the direction for force applied.

Solution 20:

- (a) Multiply force: a movable pulley.
- (b) Multiply speed: gear system or class III lever.
- (c) Change the direction of force applied: single fixed pulley.

Question 21:

State whether the following statements are true or false:

- (a) The velocity ratio of a single fixed pulley is always more than 1.
- (b) The velocity ratio of a single movable pulley is always 2.
- (c) The velocity ratio of a combination of n movable pulleys with a fixed pulley is always 2^n .
- (d) The velocity ratio of a block and tackle system is always equal to the number of strands of the tackle supporting the load.

Solution 21:

- (a) The velocity ratio of a single fixed pulley is always more than 1. **(false)**
- (b) The velocity ratio of a single movable pulley is always 2. **(true)**
- (c) The velocity ratio of a combination of n movable pulleys with a fixed pulley is always 2^n . **(true)**
- (d) The velocity ratio of a block and tackle system is always equal to the number of strands of the tackle supporting the load. **(true)**

MULTIPLE CHOICE TYPE:**Question 1:**

A Single fixed pulley is used because it:

- (a) has a mechanical advantage greater than 1.
- (b) has a velocity ratio less than 1
- (c) gives 100% efficiency
- (d) helps to apply the effort in a convenient direction.

Solution 1:

It helps in applying effort in a convenient direction.

Explanation: A single fixed pulley though does not reduce the effort but helps in changing the direction of effort applied. As it is far easier to apply effort in downward direction, the single fixed pulley is widely used.

Question 2:

The mechanical advantage of an ideal single movable pulley is:

- (a) 1
- (b) 2
- (c) less than 2
- (d) less than 1

Solution 2:

The mechanical advantage of an ideal single movable pulley is 2.

Derivation: Consider the diagram given below:

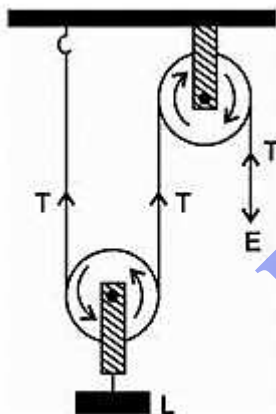

Here the load L is balance by the tension in two segments of the string and the effort E balances the tension T at the free end, so

$$L = T + T = 2T \text{ and } E = T$$

Assumption: Weight of the pulley is negligible.

We know that,

$$M.A = \frac{\text{Load (L)}}{\text{Effort (E)}} = \frac{2T}{T} = 2$$

Thus, a single movable pulley has a M.A. equal to 2.

Question 3:

A movable pulley is used as:

- (a) force multiplier
- (b) speed multiplier
- (c) device to change the direction of effort
- (d) all the above

Solution 3:

Force multiplier

Explanation: The mechanical advantage of movable pulley is greater than 1. Thus, using a single movable pulley, the load can be lifted by applying an effort equal to half the load (in ideal situation), i.e. the single movable pulley acts as a force multiplier.

NUMERICALS:**Question 1:**

A Woman draws water from a well using a fixed pulley. The mass of bucket and water together is 6 kg. The force applied by the woman is 70 N. Calculate the mechanical advantage. (Take $g = 10 \text{ m s}^{-2}$)

Solution 1:

The force applied by the women is = 70 N

The mass of bucket and water together is = 6 kg

Total load = $6 \times 10 = 60 \text{ N}$

Mechanical advantage $M.A = \frac{\text{Load}}{\text{Effort}} = \frac{60}{70} = 0.857$

Question 2:

A fixed pulley is driven by a 100 kg mass falling at a rate of 8.0 m in 4.0s. It lifts a load of 500 kgf.

- (a) Calculate the power input to the pulley taking the force of gravity on 1 kg as 10 N.
- (b) If the efficiency of the pulley is 75%, find the height to which the load is raised in 4.0s.

Solution 2:

Load = 500 kgf

Mass of falling object = 100 kg

Displacement of effort = 8.0 m

Time taken = 4.0s

(a) Effort = $100 \times 10 = 1000 \text{ kgf}$

$$\text{Power Input} = \frac{\text{displacement} \times \text{effort}}{\text{time}} = \frac{8 \times 1000}{4} = 2000 \text{ W}$$

(b) The efficiency of the pulley is = $75\% = 0.75$

$$\text{Mechanical advantage of this system } M.A = \frac{\text{Load}}{\text{Effort}} = \frac{500}{100} = 5$$

$$\text{Velocity ratio of this system } V.R = \frac{M.A}{\eta} = \frac{5}{0.75} = \frac{20}{3}$$

$$\text{Displacement of load } D = \frac{\text{displacement of effort}}{V.R} = \frac{3 \times 8}{20} = 1.2m$$

Question 3:

In a block and tackle system consisting of 3 pulleys, a load of 75 kgf is raised with an effort of 25 kgf. Find: (i) the mechanical advantage, (ii) velocity ratio and (iii) efficiency.

Solution 3:

Load = 75 kgf

Effort = 25 kgf

$n = 3$

$MA = \text{Load}/\text{Effort} = 75/25 = 3$

or $MA = n = 3$

velocity ratio $VR = n = 3$

Efficiency $\eta = \frac{M.A}{V.R} = \frac{3}{3} = 1$ or 100%

Question 4:

In fig. 3.38, draw a tackle to lift the load by applying the force in the downward direction. Mark the position of load and effort.

(a) If the load is raised by 1 m, through what distance will the effort move?

(b) State how many strands of tackle are supporting the load?

(c) What is the mechanical advantage of the system?

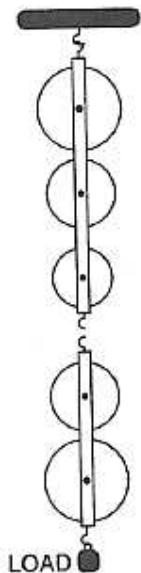

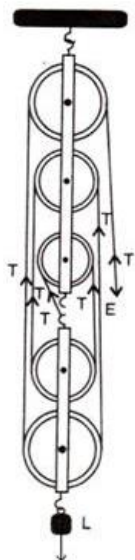
Solution 4:

- (a) The effort move = $1 \times 5 = 5\text{m}$
 (b) Five strands of tackle are supporting the load.
 (c) Mechanical advantage of the system = $M.A = \frac{\text{load}}{\text{effort}} = \frac{5T}{T} = 5$

Question 5:

A block and tackle system has 5 pulleys. If an effort of 1000 N is needed in the downward direction to raise a load of 4500 N, calculate:

- (a) the mechanical advantage
 (b) the velocity ratio, and
 (c) the efficiency of the system

Solution 5:

A block and tackle system has 5 pulleys. ($n = 5$)

Effort = 1000 N

Load = 4500 N

- (a) The mechanical advantage $M.A = \frac{\text{load}}{\text{effort}} = \frac{4500}{1000} = 4.5$
 (b) The velocity ratio = $n = 5$
 (c) The efficiency of the system $\eta = \frac{M.A}{V.R} = \frac{4.5}{5} = 0.9$ or 90%

Question 6:

A pulley system has a velocity ratio 3 and an efficiency of 80%. Draw a labelled diagram of this pulley system Calculate:

- (a) the mechanical advantage of the system and

(b) the effort required to raise a load of 300 N.

Solution 6:

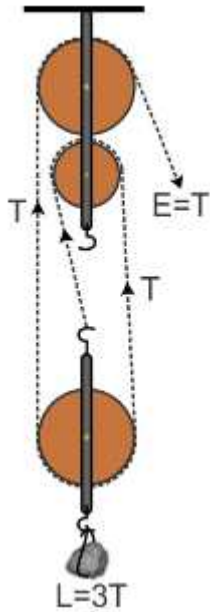

A pulley system has a velocity ratio = 3

Efficiency of system = 80 % = 0.8

Mechanical advantage of the system $M.A = V.A \times \eta = 3 \times 0.8 = 2.4$

Effort required to raise the load = Effort = $\frac{Load}{M.A} = \frac{300}{2.4} = 125N$

Question 7:

Fig 3.39 shows a system of four pulleys, The upper two pulleys are fixed and the lower two are movable.

- Draw a string around the pulleys. Also show the place and direction in which the effort is applied.
- What is the velocity ratio of the system?
- How are load and effort of the pulley system related?
- What assumption do you make in arriving at your answer in part(c)?

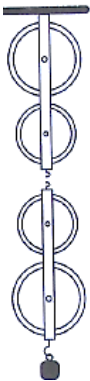

Solution 7:

(a)

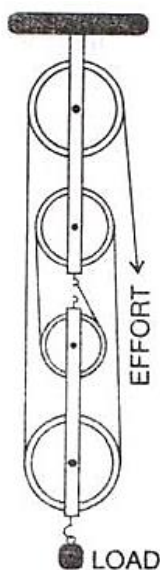
(b) Velocity ratio of the system = $n = 4$

(c) The relation between load and effort

$$MA = \frac{\text{Load}}{\text{effort}} = n = 4$$

(d)

- (i) There is no friction in the pulley bearing.
- (ii) weight of lower pulleys is negligible and
- (iii) the effort is applied downwards.

Question 8:

Fig 3.40 shows a block and tackle system of pulleys used to lift a load.

- (a) How many strands of tackle are supporting the load?
- (b) Draw arrows to represent tension in each strand.
- (c) What is the mechanical advantage of the system?
- (d) When load is pulled up by a distance 1 m, how far does the effort end move?

Solution 8:

- (a) There are 4 strands of tackle supporting the load.
- (b)

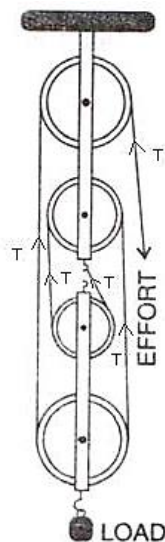

(c) The mechanical advantage of the system

$$MA = \frac{\text{Load}}{\text{effort}} = \frac{4T}{T} = 4$$

(d) When load is pulled up by a distance 1 m, the effort end will move by a distance = $1 \times 4 = 4\text{m}$.

Question 9:

A block and tackle system has the velocity ratio 3. Draw a labelled diagram of the system indicating the points of application and the directions of load and effort. A man can exert a pull of 200 kgf. What is the maximum load he can raise with this pulley system if its efficiency is 60%?

Solution 9:

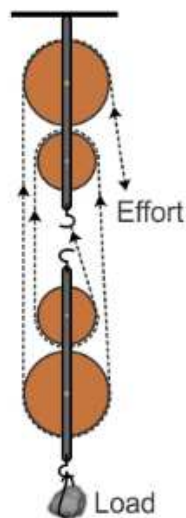

A block and tackle system has the velocity ratio = 3
i.e., $VR = n = 3$

Efficiency of system $\eta = 60\% = 0.6$

The mechanical advantage of the system $MA = V.A \times \eta = 3 \times 0.6 = 1.8$

Man can exert a maximum effort = 200 kgf

Load = M.A. \times effort = $1.8 \times 200 = 360$ kgf

Question 10:

You are given four pulleys and three strings. Draw a neat and labelled diagram to use them so as to obtain a maximum mechanical advantage equal to 8. In your diagram make the directions of load, effort and tension in each strand.

What assumptions have you made to obtain the required mechanical advantage?

Solution 10:

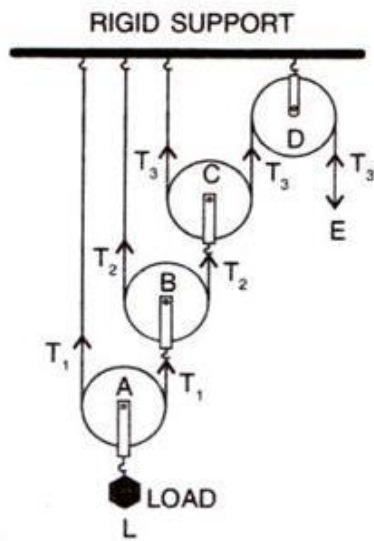

Assumptions:

- (i) There is no friction in the pulley bearing,
- (ii) the pulleys and the string are massless.