

Chapter 10. Magnetism

Exercise 10(A)

Solution 1S.

Lodestone is an ore of iron oxide (Fe_3O_4). This ore attracts small pieces of iron and it sets itself along a definite direction when it is suspended freely. It is a natural magnet which was used for the navigation by the mariners.

Solution 2S.

The pieces of lodestone found in nature are called the natural magnets. Limitations of a natural magnet are as listed below:

1. They are irregular and odd shaped.
2. They are not magnetically very strong.

Solution 3S.

An artificial magnet is a magnetized piece of iron (or other magnetic material). Artificial magnets are required because natural magnets have odd and irregular shape and they are not magnetically very strong. Artificial magnets can be given desired shape and made very strong.

Solution 4S.

Iron rod is magnetized when placed near a bar magnet by magnetic induction, while copper rod is not magnetized.

Solution 5S.

A magnet when suspended freely will rest only in north-south direction, but the soft iron bar will rest in any direction.

Solution 6S.

- (a) Poles, (b) Attract, repel,
(c) At the middle, (d) North – South

Solution 7S.

If a small magnet is suspended by a silk thread such that it can swing freely then it rests itself in the geographic north-south direction.

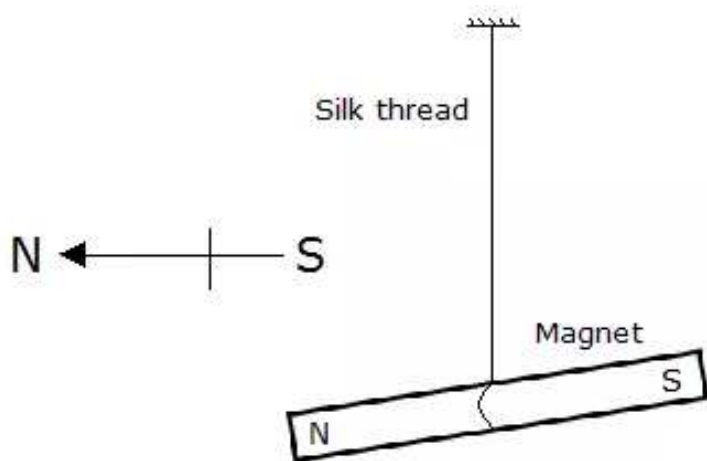

Solution 8S.

The magnetism acquired by a magnetic material when it is kept near (or in contact with) a magnet, is called induced magnetism.

Solution 9S.

The process in which a piece of magnetic material acquires the magnetic properties temporarily in presence of another magnet near it is called the magnetic induction.

When a piece of iron is placed near or in contact with a magnet, the piece of iron becomes a magnet i.e., it acquires the property of attracting iron filings when they are brought near its ends. Thus, a piece of iron behaves as a magnet as long as it is kept near (or in contact with) a magnet.

Solution 10S.

When iron nails are brought near one end of a magnet, the nearer end of piece acquires an opposite polarity by magnetic induction. Since unlike poles attract each other, therefore, iron nails are attracted towards the end of the magnet. Thus, the iron nail first becomes a magnet by induction and then it is attracted.

Solution 11S.

(a) When two pins are hung by their heads from the same pole of a magnet, they acquire same polarity. Because like poles repel each other, their pointed ends move apart.

(b) Several soft iron pins can cling one below the other from the pole of a magnet because the magnet induces magnetism in an iron nail which gets attracted by the magnet and clings to it. This magnetized nail magnetizes the other nail near it by magnetic induction and attracts it. This process continues until force of attraction on first nail is sufficient to balance the total weight of all nails in chain.

(c) When a piece of soft iron is placed a little distance away from the needle, the needle induces magnetism to the piece of soft iron. Thus, soft iron piece starts behaving like a magnet and it attracts the magnetic needle towards it.

Solution 12S.

The iron bar acquires magnetism due to magnetic induction.

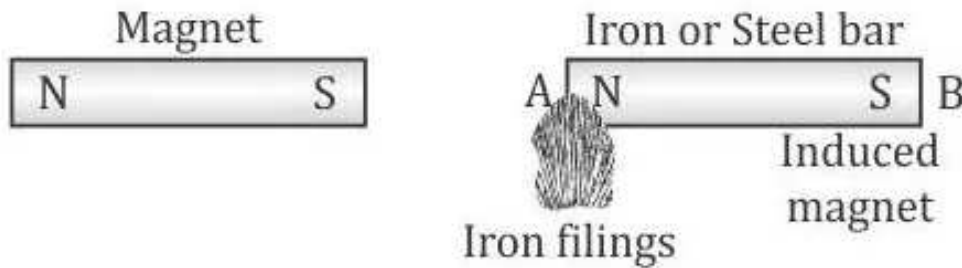

If the magnet is removed, the iron bar loses its magnetism.

Solution 13S.

Induced magnetism is temporary as it lasts as long as the magnet causing induction remains in its vicinity.

Solution 14S.

When a piece of magnetic material is brought near a magnet, it first becomes a magnet by induction and then it is attraction. Thus, we say that induction precedes attraction.

Solution 15S.

A magnetic field line is a continuous curve in a magnetic field such that tangent at any point of it gives the direction of the magnetic field at that point.

Solution 16S.

Properties of magnetic field lines:

1. They are closed and continuous curves.
2. They are directed from the North Pole towards the South Pole outside the magnet.
3. The tangent at any point on a field line gives the direction of magnetic field at that point.
4. Two magnetic lines never intersect each other.

Solution 17S.

The iron filings take up a definite pattern (curved lines). This happens because each piece of iron filing becomes a magnet to the magnetic induction of the magnet. It thus experiences a force in the direction of magnetic field of the bar magnet at that point and aligns itself along curved lines.

Solution 18S.

Method of plotting the magnetic field lines using a compass needle:

Fix a sheet of paper on a drawing board by means of board pins. Place a small compass needle at position 1 as shown in fig (a) and looking from the top of the needle, mark two pencil dots exactly at two ends of the needle. Then move the compass needle to position

2 in such a way that one end of needle coincides with the second pencil dot. Repeat the process of moving the compass needle to positions 3, 4,... to obtain several dots. On joining the different dots, you will get a straight line. Thus one line of magnetic field of earth is traced.

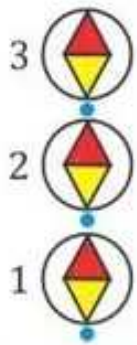

(a) Plotting a field line with a compass needle

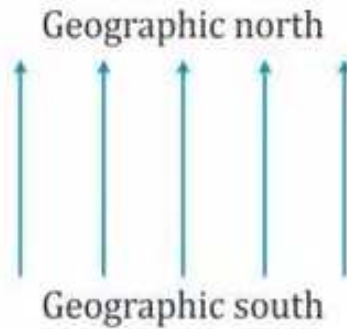

(b) Lines of uniform magnetic field of earth

This process is repeated starting from a different point and tracing out another line of magnetic field. In this manner, several lines of magnetic field can be drawn. Each line should be labeled with an arrow from the south pole of the needle towards the north pole to indicate the direction of the magnetic field. Fig (b) shows several magnetic lines so obtained.

Solution 19S.

No two magnetic field lines can intersect each other. If they do, there would be two directions of the field at that point which is not possible.

Solution 20S.

In (a) The North Pole of two magnets is facing each other. So, the field lines will be

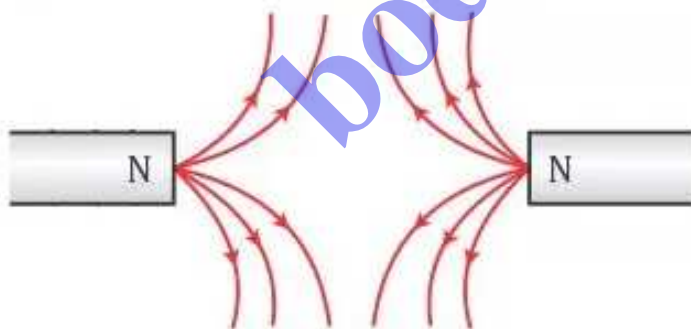

In (b) The North Pole of one magnet is facing the South Pole of the other. So, the field lines will be

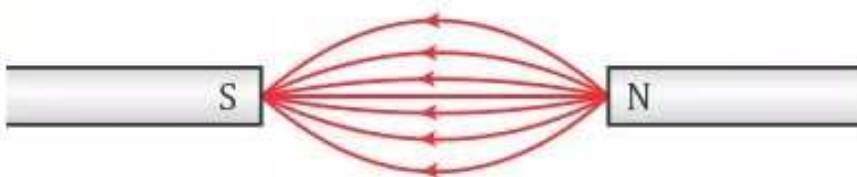

Solution 21S.

Two evidences of existence of earth's magnetic field:

1. A freely suspended magnetic needle always rests in geographic north-south direction.
2. Neutral points are obtained on plotting the field lines of a magnet.

Solution 22S.

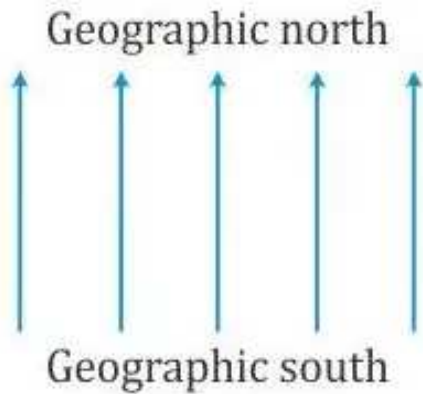

Solution 23S.

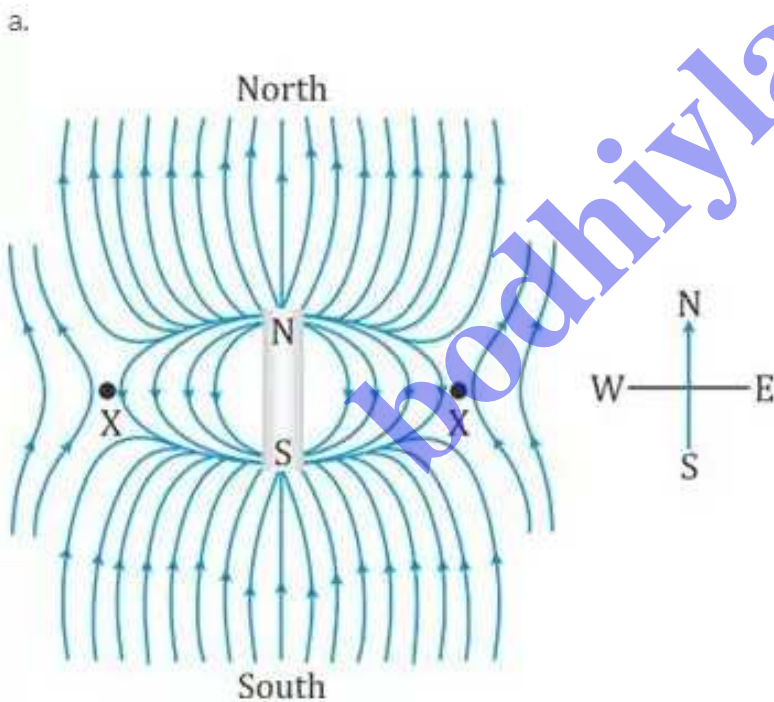

b. The magnetic field lines are non-uniform in nature.

Solution 24S.

(a)

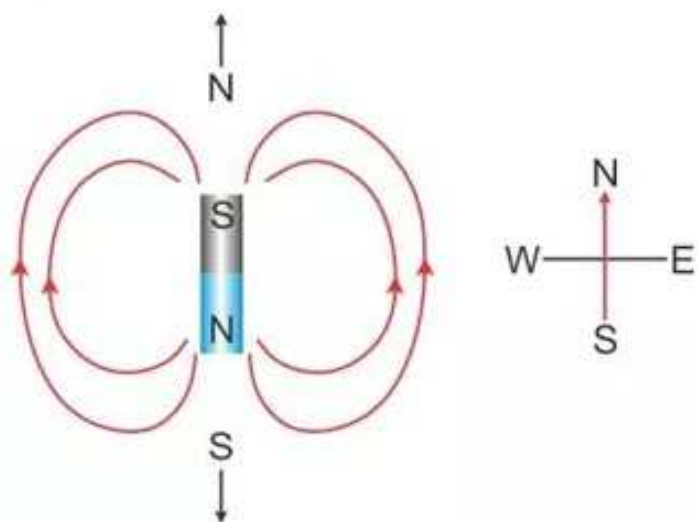

(b)

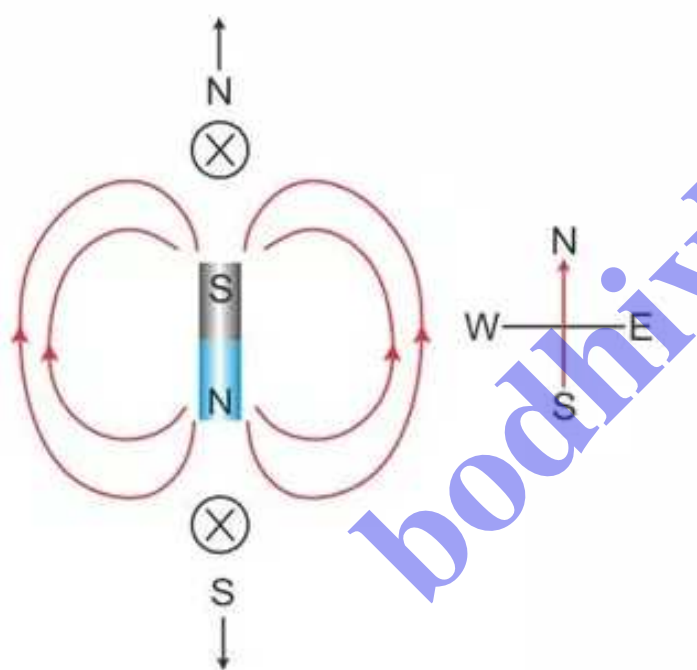

(c) Magnitude of magnetic field at neutral points is zero. It is so because at these points, the magnetic field of the magnet is equal in magnitude to the earth's horizontal magnetic field, but it is in opposite direction. Hence, they cancel each other.

Solution 25S.

It can be concluded that magnetic field at that point is zero. This is because the earth's magnetic field at that point is neutralized by the magnetic field of some other magnetized material.

Solution 26S.

Neutral points are the points where the magnetic field of the magnet is equal in magnitude to the earth's horizontal magnetic field, but it is in opposite direction. Thus the net magnetic field at the neutral points is zero.

Since the net magnetic field is zero at neutral points, the compass needle remains unaffected (i.e. it comes to rest pointing in any direction) at these points and hence, they can be detected.

Solution 27S.

- (i) Neutral points will be in east-west direction.
- (ii) Neutral points will be north-south direction.

Solution 28S.

(a) Uniform, (b) Zero and (c) On either side of the magnet in east and west.

Solution 1M.

Repel each other

Solution 2M.

Parallel equidistant straight lines

Exercise 10(B)

Solution 1S.

An electromagnet is a temporary strong magnet made from a piece of soft iron when current flows in the coil wound around it. It is an artificial magnet.

Solution 2S.

The material used for preparing an electromagnet is soft iron.

Solution 3S.

An electromagnet is made by winding an insulated copper wire around a soft iron core either in the shape of a solenoid or U-shape.

The strength of magnetic field of an electromagnet depends on:

1. The number of turns of wire wound around the coil, and
2. The amount of current flowing through the wire.

Solution 4S.

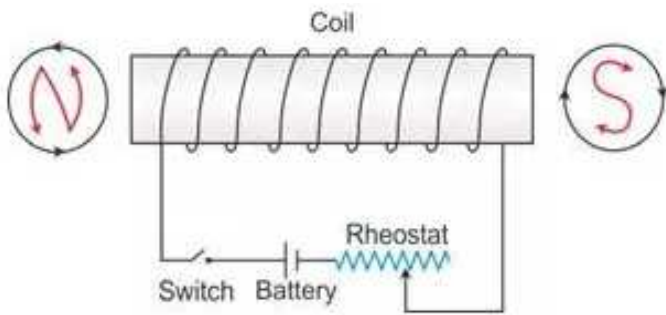

Solution 5S.

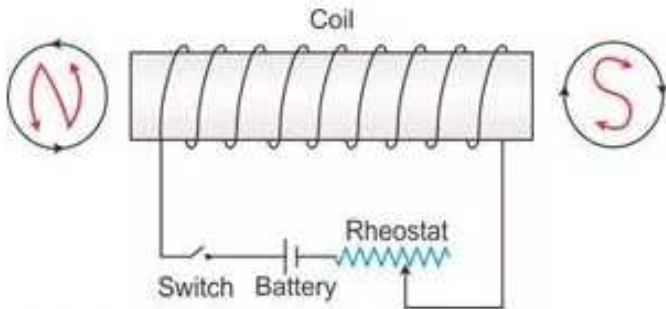

The polarity at X is North and at Y is South.

By increasing the number of turns of winding in the solenoid, the strength of the electromagnet can be increased.

Solution 6S.

The device formed is an electromagnet.

Use: For separating the magnetic substances such as iron from other debris.

Solution 7S.

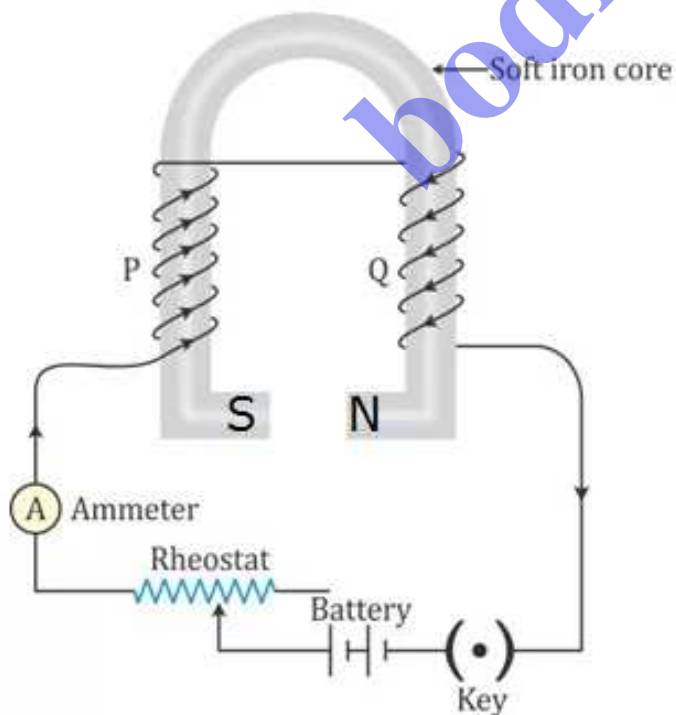

Solution 8S.

The strength of an electromagnet can be increased by following ways:

1. Increasing the number of turns of winding in the solenoid.
2. Increasing the current through the solenoid.

Solution 9S.

The electromagnet is used in an electric relay.

Solution 10S.

1. An electromagnet can produce a strong magnetic field.
2. The strength of the magnetic field of an electromagnet can easily be changed by changing the current in its solenoid.

Solution 11S.

Electromagnet	Permanent magnet
It is made up of soft iron	It is made up of steel
The magnetic field strength can be changed	The magnetic field strength cannot be changed
Electromagnets of very strong field can be made.	Permanent magnets are not so strong.

Solution 12S.

The soft iron bar acquires the magnetic properties only when an electric current flows through the solenoid and loses the magnetic properties as the current is switched off. Hence, soft iron is used as the core of the electromagnet in an electric bell.

Solution 13S.

If an a.c. source is used in place of a battery, the core of the electromagnet will get magnetized, but the polarity at its ends will change. Since attraction of armature does not depend on the polarity of the electromagnet, the bell will still ring on pressing the switch.

Solution 14S.

The material used for making the armature of an electric bell is soft iron which can induce magnetism rapidly.

Solution 1M.

Electromagnets are made up of soft iron.

Solution 2M.

The strength of an electromagnet can be increased by

1. increasing the number of turns of coil, and
2. increasing the current through the coil
3. Hence, the correct answer is option c.

bodhiyla.com