

19. Visualising Shapes

Exercise 19.1

1. Question

What is the least number of planes that can enclose a solid? What is the name of the solid?

Answer

Four planes are required to enclose a solid.

The name of solid is tetrahedron.

2. Question

Can a polyhedron have for its faces?

(i) 3 triangles?

(ii) 4 triangles?

(iii) a square and four triangles?

Answer

(i) 3 triangles?

No, Because a polyhedron is a solid shape bounded by polygons.

(ii) 4 triangles?

Yes, Because four triangles will form a tetrahedron, which is a polygon.

(iii) a square and four triangles?

Yes, because a square pyramid has a square and four triangles as its faces. Since pyramid is a polyhedron whose base is a polygon of any number of sides and whose other faces are triangles with common vertex.

3. Question

Is it possible to have a polyhedron with any given number of faces?

Answer

Yes, if number of faces is four or more.

For example pyramid is a polyhedron whose base is a polygon of any number of sides and whose other faces are triangles with common vertex.

4. Question

Is a square prism same as a cube?

Answer

Yes, a square is a three dimensional shape with six rectangular shaped sides, at least two of which are squares. Cubes are rectangular prisms length, width and height of same measurement.

5. Question

Can a polyhedron have 10 faces, 20 edges and 15 vertices?

Answer

No,

Using Euler's formula

$$V + F = E + 2$$

$$15 + 10 = 20 + 2$$

$$25 \neq 22$$

Since the given polyhedron is not following Euler's formula, therefore its not possible.

6. Question

Verify Euler's formula for each of the following polyhedrons:

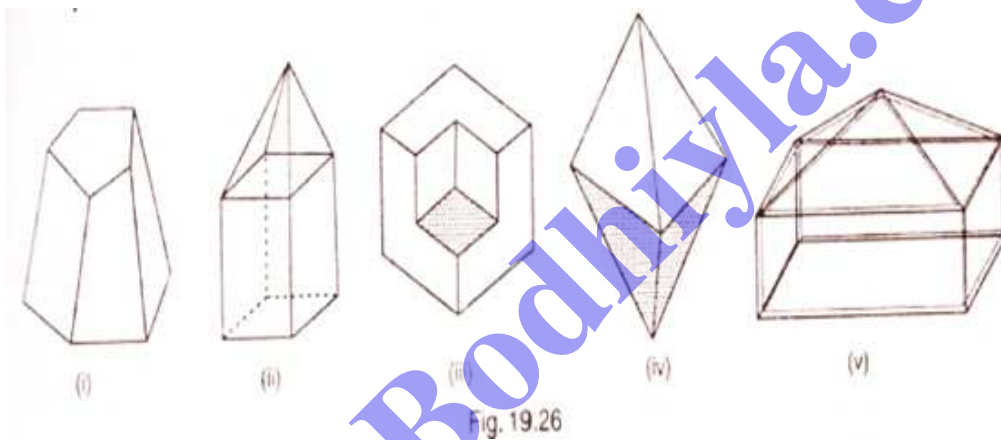

Answer

(i) Vertices = 10

Faces = 7

Edges = 15

$$V + F = E + 2$$

$$10 + 7 = 15 + 2$$

$$17 = 17$$

(ii) Vertices = 9

Faces = 9

Edges = 16

$$V + F = E + 2$$

$$9 + 9 = 16 + 2$$

$$18 = 18$$

(iii) Vertices = 14

Faces = 8

Edges = 20

$$V + F = E + 2$$

$$14 + 8 = 20 + 2$$

$$22 = 22$$

(iv) Vertices = 6

Faces = 8

Edges = 12

$$V + F = E + 2$$

$$6 + 8 = 12 + 2$$

$$14 = 14$$

(v) Vertices = 9

Faces = 9

Edges = 16

$$V + F = E + 2$$

$$9 + 9 = 16 + 2$$

$$18 = 18$$

7. Question

Using Euler's formula find the unknown:

Bodhiyla.com

Faces	?	5	20
Vertices	6	?	12
Edges	12	9	?

Answer

(i) $V + F = E + 2$

$6 + F = 12 + 2$

$F = 14 - 6$

$F = 8$

Therefore number of faces are 8

(ii) $V + F = E + 2$

$V + 5 = 9 + 2$

$V = 11 - 5$

$V = 6$

Therefore number of vertices are 6

(iii) $V + F = E + 2$

$12 + 20 = E + 2$

$E = 32 - 2$

$E = 30$

Therefore number of edges are 30

Exercise 19.2

1. Question

Which among of the following are nets for a cube?

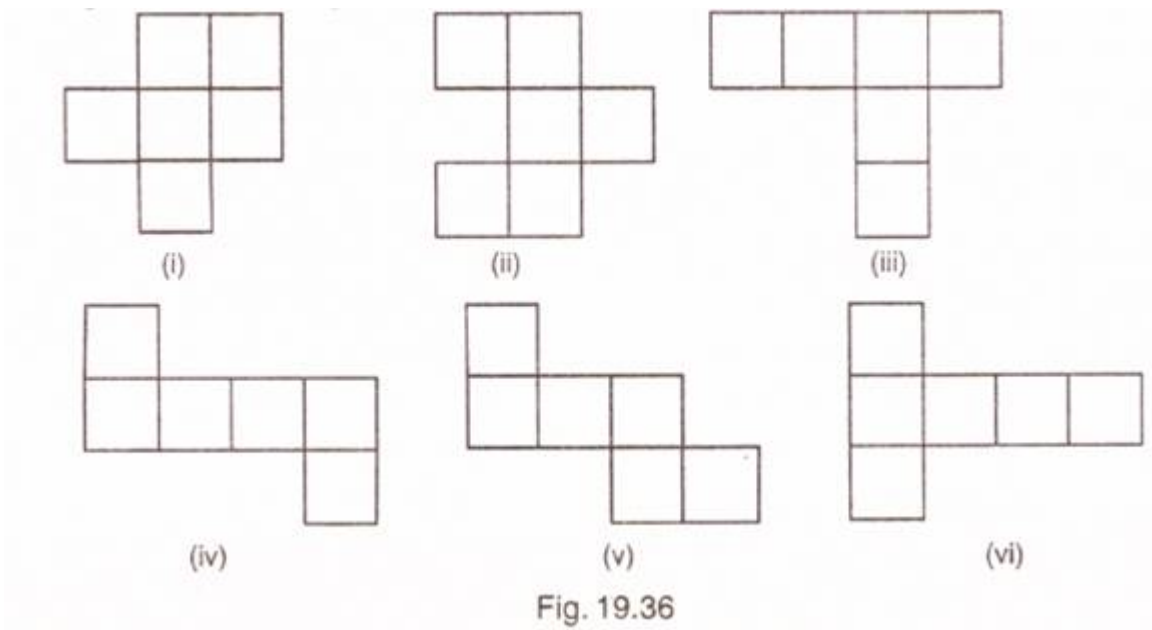
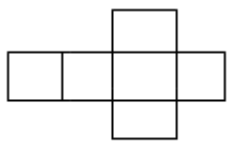

Fig. 19.36

Answer

Figure (iii) and (vi) are the nets of a cube.



Net of a cube

2. Question

Name the polyhedron that can be made by folding each net:

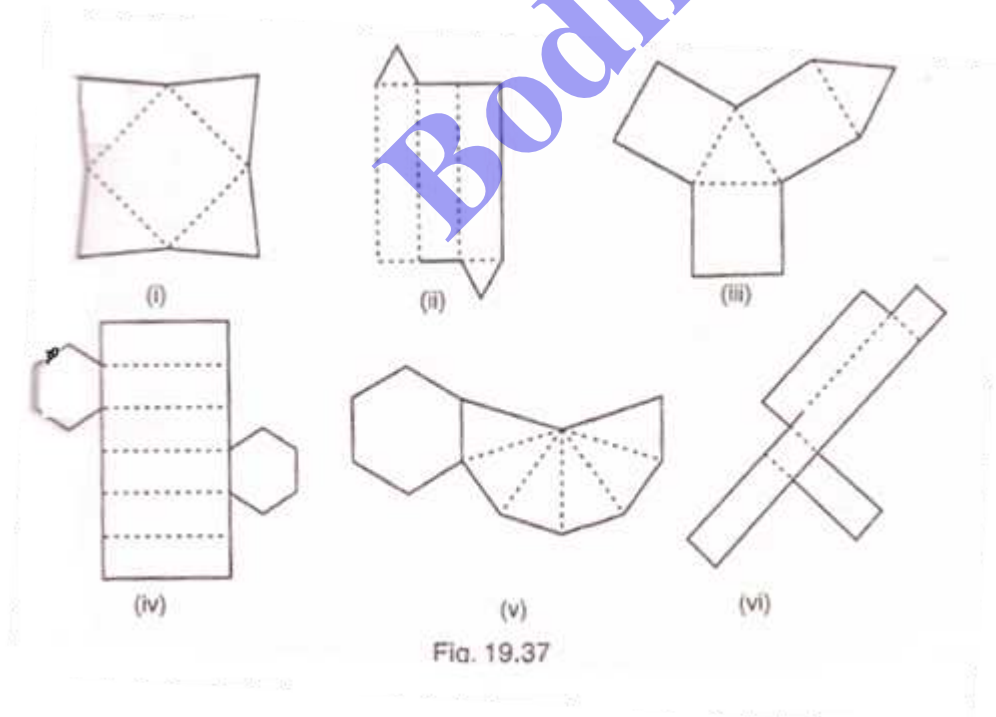

Fig. 19.37

Answer

- (i) From first figure Square pyramid can be made
- (ii) From second figure Triangular prism can be made
- (iii) From third figure Triangular prism can be made
- (iv) From fourth figure Hexagonal prism can be made
- (iv) From fifth figure Hexagonal pyramid can be made
- (v) From fifth figure Cube can be made

3. Question

Dice are cubes where the numbers on the opposite faces must total 7. Which of the following are dice?

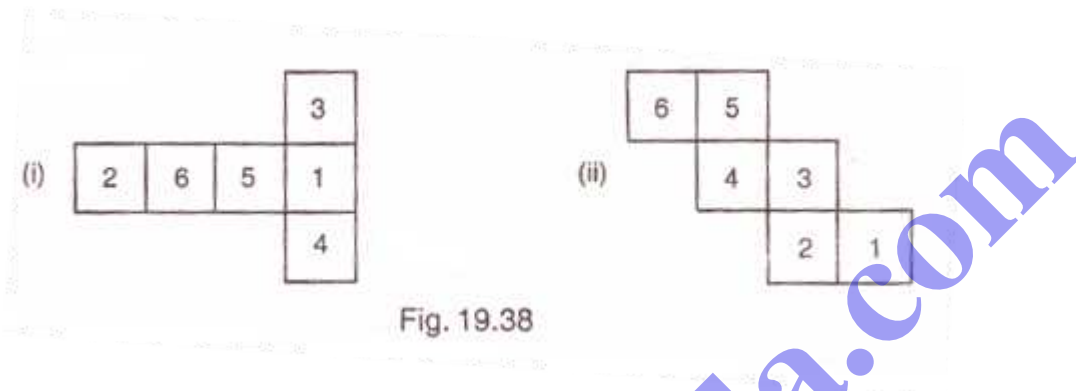

Answer

Fig (i) is a dice because the sum of numbers on opposite faces is 7 ($3 + 4 = 7$ and $6 + 1 = 7$).

4. Question

Draw nets for each of the following polyhedrons:

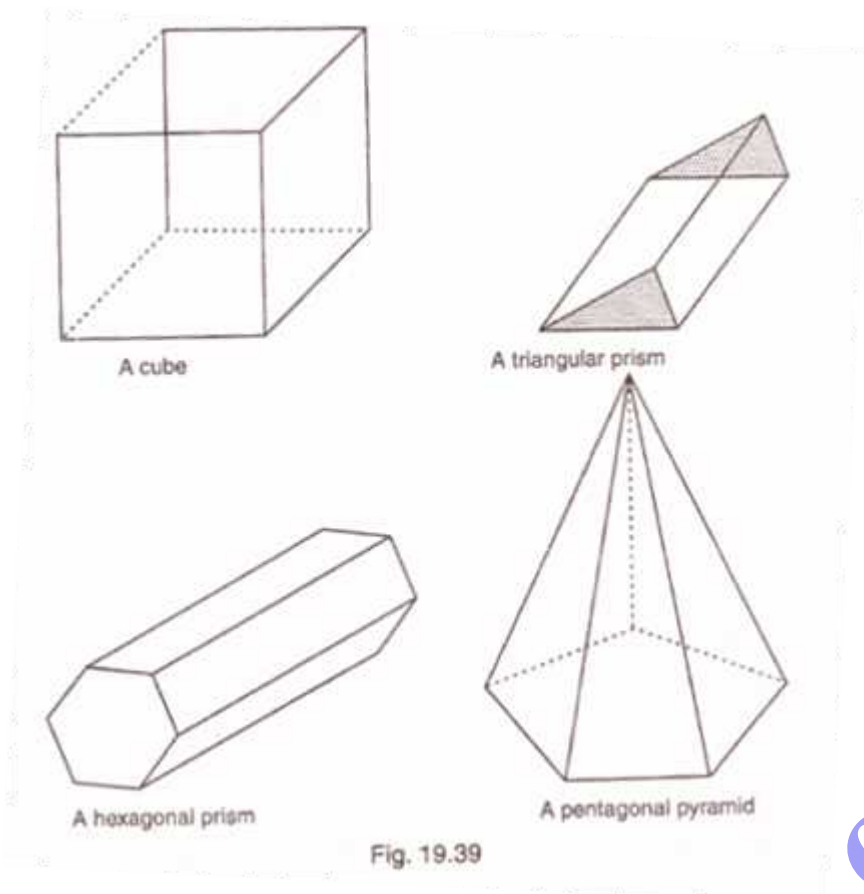

Answer

(i) Net pattern of a cube:

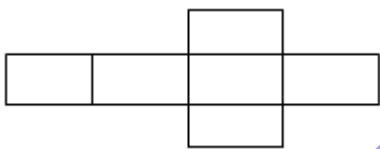

(ii) Net pattern of Triangular prism:

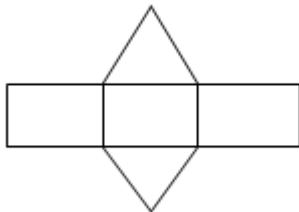

(iii) Net pattern of Hexagonal prism:

5. Question

Match the following figures:

Prisms

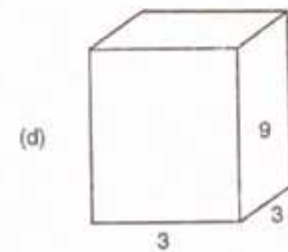
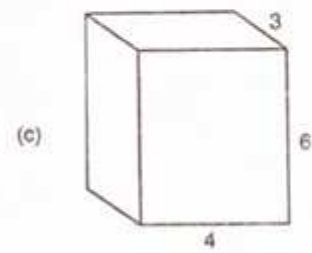
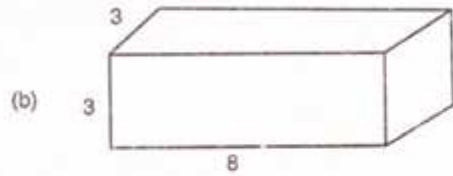
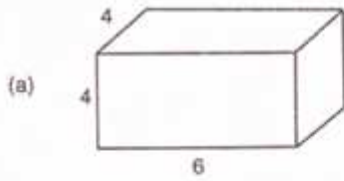

Nets with areas of faces

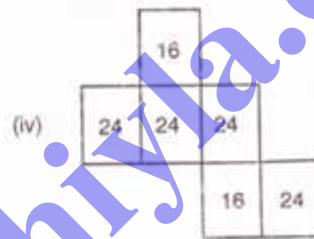
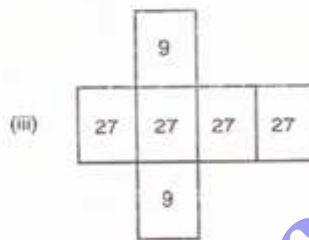
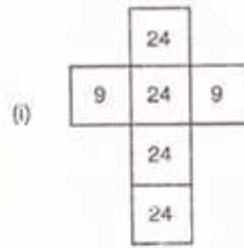

Fig. 19.40

Answer

(a)—(iv) Because multiplication of numbers on adjacent faces are equal, i.e. $6 \times 4 = 24$ and $4 \times 4 = 16$

(b)—(i) Because multiplication of numbers on adjacent faces are equal, i.e. $3 \times 3 = 9$ and $8 \times 3 = 24$

(c)—(ii) Because multiplication of numbers on adjacent faces are equal, i.e. $6 \times 4 = 24$ and $6 \times 3 = 18$

(d)—(iii) Because multiplication of numbers on adjacent faces are equal, i.e. $3 \times 3 = 9$ and $3 \times 9 = 27$